

Secure Safe Trend I

for protection of cash and valuables

• £1,000 cash rating

For some homeowners and small businesses, the requirement is for a quality cash safe within a limited budget. A solution which securely protects a wide range of valuables (e.g. jewellery, camera and passports). The most cost-efficient solution is the Secure Safe Trend I from SecureLine. Based on a steel construction, the safe offers £1000 cash rating, electronic LCD locking, removable shelf, fixing kit and a choice of six sizes. Combining so many quality features at a low price illustrates SecureLine's position as the only budget security brand to own. Many would agree...

Models

- The Secure Safe Trend I is available in six models, all designed to hold cash and valuables
- For storing binders we recommend model 44 in which the binders can be stored vertically



Construction

- The Trend I range is constructed with an 8 mm solid steel door and 3 mm steel body. Increased security is achieved by hardened steel plates which protect lock, bolt-work and bolts against drilling
- The durable bolt-work has 2 or 4 bolts, which are chrome plated and have a diameter of 25 mm

Locking

- The safes are available with a double bitted key lock or electronic PIN-code lock (6 digits) with a LCD-display
- Override key supplied with electronic version

Additional features

- Fixing kit allows DIY securing of safe to floor and/or wall
- In addition the safes are supplied with a removable shelf as standard (except model 18)

Design

- The Trend range has modern styling and will complement any user environment
- The safes are in two-tone colour powder coated finish; light grey and dark grey



from **Chubb**safes



Secure Safe Trend I

Models

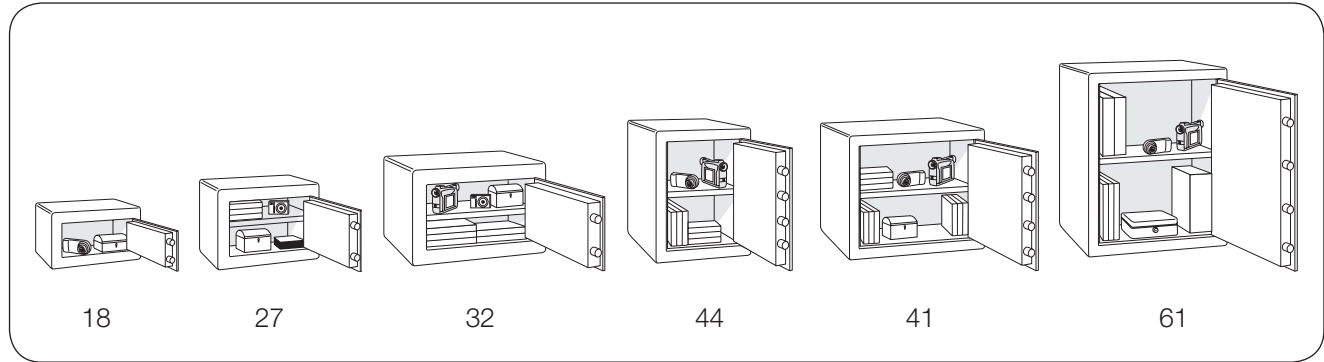

Product data

Key lock

Model	Article No.	External dimensions (mm)

Electronic lock

Model	Article No.	External dimensions (mm)

SecureLine policy is one of constant improvement. The above specification may therefore be altered without prior notification.



from **Chubb**safes

Authorised dealer:

www.Chubb-Safe.co.uk

0800 6129456