

Secure Safe Trend II

for protection of documents, cash and valuables

• **£3,000 cash rating**

Faced with increasing threats to security, homeowners and small businesses are constantly striving for products offering the best possible value. One possible solution is the "Secure Safe Trend II" from SecureLine. This cash safe is an enhanced version of the Trend I with a higher cash rating (£3,000) and 30 minutes fire protection. Other notable features include steel construction, hardened "anti-drilling" steel plates, electronic LCD locking, removable shelf and a fixing kit. With so many benefits, it's no surprise the safe has rapidly grown in popularity...

Models

- The Secure Safe Trend II is available in six models, all designed to hold cash and valuables and to store documents
- For storing binders we recommend model 44 in which the binders can be stored vertically

Construction

- The Trend II range has a double wall construction, 3 mm external and 2 mm internal and an 8 mm solid steel door
 - Offers 30 minutes fire protection for paper. Barrier material tested to DIN 4102
 - Increased security is achieved by hardened steel plates which protect the lock, bolt-work and bolts against drilling
 - The durable bolt-work has 2 or 4 bolts, which are chrome plated and have a diameter of 25 mm

Locking

- The safes are available with a double bitted key lock or electronic PIN-code lock (6 digits) with a LCD-display
- Available with double bitted key lock or electronic LCD display

Additional features

- Fixing kit allows DIY securing of safe to floor and/or wall
- In addition the safes are supplied with a removable shelf as standard (except model 18)

Design

- The Trend range has modern styling and will complement any user environment
- The safes are in two-tone colour powder coated finish, light grey and dark grey



from **Chubb**safes



Secure Safe Trend II

Models

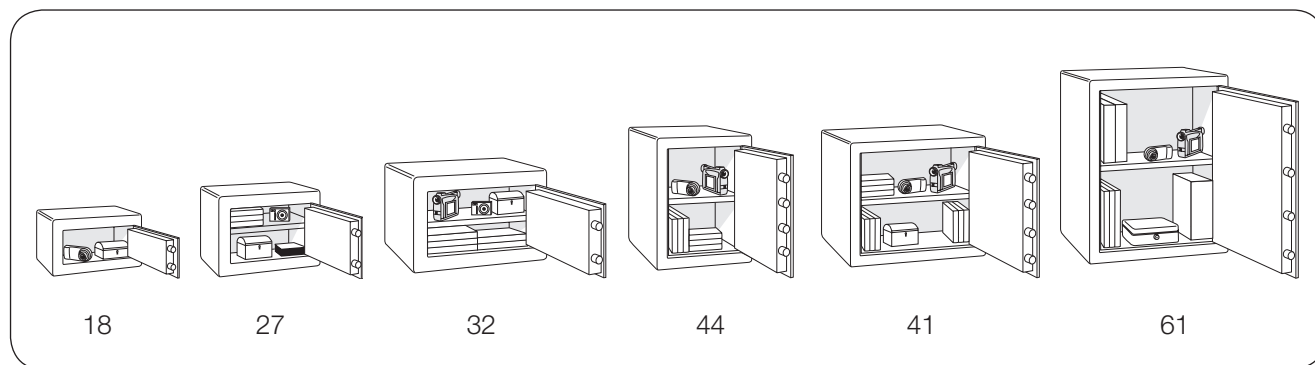

Product data

Key lock

Model	Article No.	External dimensions (mm)			Internal dimensions (mm)			Volume (litres)	Weight (kg)	Shelf (qty)	Bolts (qty)	Fire Rating (mins)
		Height	Width	Depth	Height	Width	Depth					
TII-18K	SL02500	180	310	205	100	230	110	3	16	N/A	2	30
TII-27K	SL02501	270	350	345	190	270	250	13	28	1	2	30
TII-32K	SL02502	320	440	395	240	360	300	26	45	1	2	30
TII-44K	SL02503	440	320	395	360	240	300	26	45	1	4	30
TII-41K	SL02504	410	460	395	330	380	300	38	54	1	4	30
TII-61K	SL02505	610	460	395	530	380	300	60	73	1	4	30

Electronic lock

Model	Article No.	External dimensions (mm)			Internal dimensions (mm)			Volume (litres)	Weight (kg)	Shelf (qty)	Bolts (qty)	Fire Rating (mins)
		Height	Width	Depth	Height	Width	Depth					
TII-27E	SL02507	270	350	345	190	270	250	13	28	1	2	30
TII-32E	SL02508	320	440	395	240	360	300	26	45	1	2	30
TII-44E	SL02509	440	320	395	360	240	300	26	45	1	4	30
TII-41E	SL02510	410	460	395	330	380	300	38	54	1	4	30
TII-61E	SL02511	610	460	395	530	380	300	60	73	1	4	30

SecureLine policy is one of constant improvement. The above specification may therefore be altered without prior notification.



from **Chubb**safes

Authorised dealer:

www.Chubb-Safe.co.uk

0800 6129456