

Secure Safe Deposit

for protection of cash and valuables

• £3,000 cash rating

The Secure Safe Deposit allows the depositing of cash and valuable items without having to first open the safe door. This makes it easier for retailers and small businesses to make deposits during working hours without putting staff or the other contents of the safe at risk. The Secure Safe Deposit offers an effective solution to the issue of how to deal with a build-up of bank notes accumulated during trading hours before banking and the problem of how to protect cash in the main safe at the close of trading.



Models

- The Secure Safe Deposit is available in two sizes. Each size is available with key locking or electronic locking

Construction

- The Secure Safe Deposit is constructed with a 10mm solid steel door plate and steel body

- The door is secured by a three way moving bolt mechanism

- The door has chrome plated, 20mm diameter bolts operating on three sides of the door

- A full height fixed plate secures the hinged side of the door

Deposit Mechanism

- The deposit mechanism is protected by three anti-fishing plates to prevent unauthorised removal of deposited items
- Deposit size maximum is 265mm x 80mm x 150mm (h x w x d)

Locking

- The choice is either a double bitted keylock or a user friendly electronic lock. The electronic lock allows multiple user codes and mechanical override

Additional features

- The safes can be anchored using the fixing kit supplied

Design

- The Secure Safe Deposit range has a two tone powder finish with a light-grey door and dark grey body. The door fascia and handle are chrome-plated



from **Chubb**safes



Secure Safe Deposit

Models

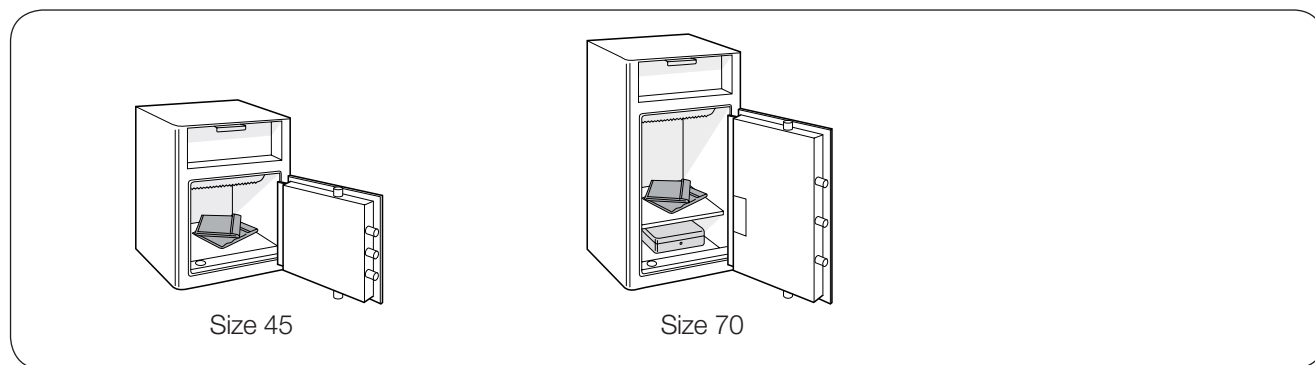

Product data

Key Lock

Model	Article No.	External dimensions (mm)			Internal dimensions (mm)			Volume (litres)	Weight (kg)	Locking	Shelf (qty)
		Height	Width	Depth	Height	Width	Depth				
SSD-45K	SL02550	455	340	380	240	325	305	24	54	Keylock	N/A
SSD-70K	SL02552	700	340	380	480	325	305	48	74	Keylock	1

Electronic Lock

Model	Article No.	External dimensions (mm)			Internal dimensions (mm)			Volume (litres)	Weight (kg)	Locking	Shelf (qty)
		Height	Width	Depth	Height	Width	Depth				
SSD-45E	SL02551	455	340	380	240	325	305	24	54	Electronic	N/A
SSD-70E	SL02553	700	340	380	480	325	305	48	74	Electronic	1

SecureLine policy is one of constant improvement. The above specification may therefore be altered without prior notification.



from **Chubb**safes

Authorised dealer:

www.Chubb-Safe.co.uk
0800 6129456